

# NEWCO IA SERIES

## A C E I N T E L L I - B R E W O P E R A T I O N S M A N U A L

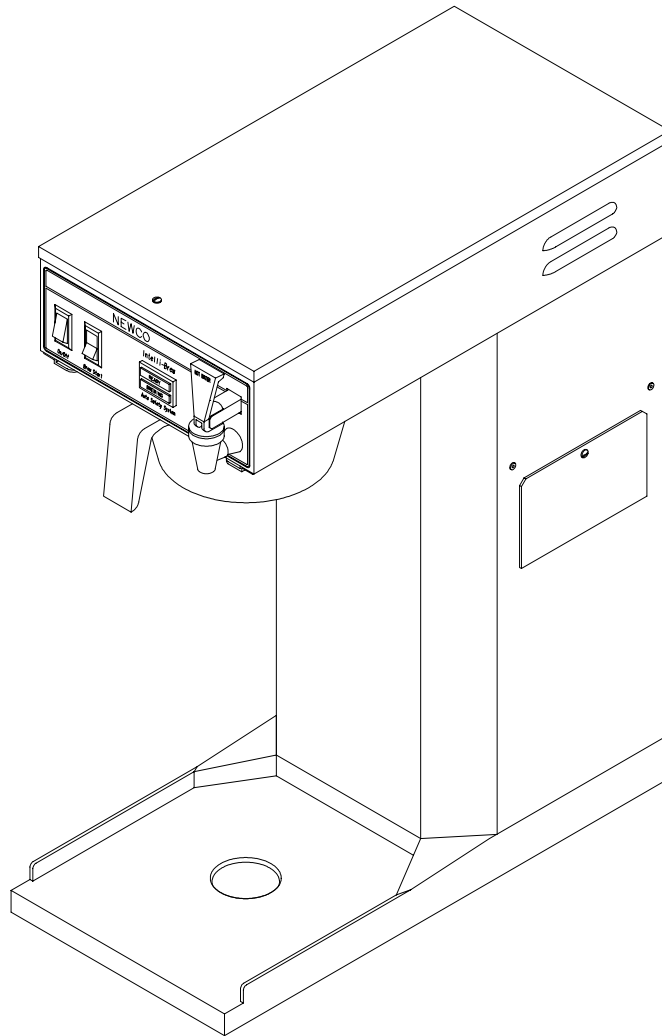

**NEWCO**   
ENTERPRISES, INC.

## INSTALLATION / SETUP INSTRUCTIONS

**WARNING:** - Read and follow installation / setup instructions before plugging or wiring in machine to electrical circuit. Warranty will be void if machine is connected to any voltage other than that specified on the name plate.

### Plumber's Installation Instructions

- 1) Plumb brewer in to water supply using 1/4 inch copper or plastic tubing. Flush water line before installing brewer to remove sediment. Brewer should be connected to COLD WATER LINE for best operation.
- 2) Water pressure should be at least 20 lbs. For less than a 25 ft run, use 1/4" tubing and connect to 1/2" or larger water line. The inlet water fitting on the back of the brewer is a 1/4" flare fitting.
- 3) If installed with saddle valve, the valve should have a minimum of 1/8" port hole for up to 25 ft run, and 5/16" port hole for over 25 ft runs.
- 4) Check for leaks

### Initial Setup Instructions

- 1) Plug or wire brewer to the appropriate voltage circuit as indicated on the serial tag. Place a suitable decanter in place below the brew basket to catch water. Depress the "On/Off" (power) switch to supply power to the control board. Depress the "Brew Start" switch and the tank will begin to fill. The tank lid has a probe in it to signal the control board when the water has reached the appropriate level to begin the timing for the brew cycle. If this probe does not see water for 3 minutes the control board will interpret this as an error. It will shutoff the solenoid valve, disable the control board and alternate flashing the heating and brewing light. The time required to fill the tank initially exceeds this time. Therefore this error will occur when the unit is initially setup. To reset the safety circuit and enable control board simply unplug the unit from the wall outlet and plug it back in. Or depress and hold lower warmer switch (power switch on thermal brewers) Approximately 5 seconds until error clears.
- 2) Turn on the power ("On/Off") switch and depress the start switch. The tank lid has a second longer probe in it which is a heater safety probe. This probe will tell the control board when the water level is high enough to supply power to the tank element. It also will call for power to be shut off to the element should the water level fall below it. If the tank temperature adjustment is in the off position or if the autoarm feature has been disabled the unit will continue to fill. Otherwise the brewer will go into the autoarm mode and the heating light will begin to flash. This indicates that the unit is in the brew mode but is not up to temperature (Note: To accelerate the set up time the "Tank Temp" Adjustment dial may be rotated to the off position momentarily until the fill cycle begins and then turned back). When the tank reaches the preset temperature the fill portion of the brew cycle will begin. The tank lid must be in place for proper unit operation.
- 3) When water begins to flow from brew basket the brew cycle may be canceled by depressing the power switch. Allow water to finish draining from the unit and then empty the decanter and replace below brew basket. Turn power switch back on and depress the brew start switch. After the brew cycle has finished check volume of water in the container. Adjust the "Brew Time" with the control board located behind right side access plate. Turn the dial Clockwise to increase the volume of water and counterclockwise to decrease it. See Fig 1 on page 5 for control board setting information.
- 4) Allow 10-15 minutes for the water in the tank to heat to brewing temperature. Depending on the "Tank Heater Mode" Selected with switch on the back of unit it may be necessary to have the power switch on for the tank to heat up to operating temperature. The heating light will go out when the unit is up to temperature. Run one brew cycle to check for the proper temperature setting with an accurate thermometer. Take the temperature of this water at a point below the brew basket opening, at the start of the brew cycle and when the decanter is half full. Recommended temperature of the water is approximately 195 F. (Note: Brew cycle may be canceled by the "On/Off" switch). The brewer features an electronic temperature control circuit and the temperature may be adjusted with the control board located behind the right side access plate. See Fig 1 on page 5 for control board setting information.
- 5) In higher altitude locations (5000 feet above sea level) the tank temperature may have to be adjusted lower to prevent boiling. Turning adjustment knob in a clockwise direction will increase water temperature. This unit features an electronic temperature control. Adjustment is located on the control board behind the right side access plate.
- 6) **CAUTION:** The water faucet will dispense hot water when the handle is pulled.

## OPERATION INSTRUCTIONS

### Coffee Preparation Procedures

- 1) Place filter into brew basket.
- 2) Put the proper amount of coffee into the filter.
- 3) Slide the brew basket into holder.
- 4) Place the appropriate empty decanter into position below the brew basket. For airpots first open lid and remove pump stem. For other dispensers remove the lid unless it is a brew through design. Turn power on by depressing the "On/Off switch located on the face plate to the left of the "Brew Start" switch.
- 5) Press brew start switch. Note: a brew cycle may be initiated even if the heating light is on.
- 6) If the autoarm feature is enabled the heating light will begin to flash indicating that the brewer is heating and will begin to brew immediately after the heating cycle is complete. Do not remove decanter. Brew cycle may be canceled by depressing the power switch. Light on power switch should go out and heating light should no longer be flashing.
- 7) Hot water will be delivered through the sprayhead. This distributes the hot water evenly over the coffee bed within the brew basket. The coffee brew will drain from the brew basket into the decanter below.
- 8) The Brewing light should continue to flash until all the liquid has finished flowing from the brew basket. Do not remove decanter until the brewing process has stopped and all liquid has stopped flowing from the brewbasket.
- 9) The resultant coffee brew should be crystal clear and have the desired properties attainable through excellent extraction.
- 10) To clean brew basket simply remove from brew rails and dump filter into waste basket. The brewing process, as described above, can now be started again.

### ACE INTELLI-BREW FEATURE DESCRIPTION

Digital Brew Timing is accurate to within .1 seconds over the entire adjustment range of 30 to 240 seconds. Brew time adjustment knob may be turned down during the brew cycle until brewing stops. Can aid in setting the unit up. See Fig 1 on page 5 for setting information.

Control Brew cycles the fill valve on and off during the brew cycle. This slows the entry of cold water into the tank and minimizes the mixing action caused by introducing a large volume of cold water into the tank at one time resulting in a 3-5 degree increase in brew temperature.

Visa-Brew continues to flash the brewing light after the fill portion of the brew cycle has stopped alerting the user that the brewed hot coffee has not finished draining from the brew basket. this popular feature has been enhanced with an autocal feature. Simply turn the adjustment dial all the way up, start a normal brew cycle as described under the "OPERATION INSTRUCTIONS", and after the brewed coffee has quit dripping from the basket turn the dial down just until the light quits flashing. Visa Brew is now custom set for your machine, filters, and coffee. See Fig 1 on page 5 for setting information.

Auto Power Save allows you to automatically save energy when the brewer is not in use for a specified length of time ranging from 30 to 240 minutes. By using the "Tank Heater Mode" switch located on the back of the brewer you may select one of the three operation modes.

Mode I is the "Power Save" mode. In this mode the tank temperature will be maintained at approximately 170 degrees when the "Run Time..." setting on the control board has been reached. Heating light will flash once every minute to indicate unit is in power save mode.

Mode II is the "Normal" mode. In this mode the tank temperature will be maintained at the temperature set on the control board at all times.

Mode III is the "Power Down" mode. In this mode the tank heater element will be disabled when the "Run Time..." setting on the control board has been reached. Brewing light will flash once every minute to indicate unit is in power down mode.

The time before switching into the selected mode is controlled by the adjustment dial on the control board labeled "Run Time Before Systems Shutdown". By depressing the brew start switch or by turning the power back on with the "On/Off" switch the timer is reinitialized and the time frame starts over. In modes I and III the "Auto Arm" feature will bring the tank up to temperature before brewing when the brew start switch is depressed. The control board has a test position at the extreme right of the adjustment range. This position is used to ensure that the brewer is switching into the selected mode. When set here the brewer will go into selected mode and power switch will turn off after 10 seconds.

Auto Arm ensures that the brewer is up to temperature prior to brewing to ensure proper extraction is obtained. If the water temperature in the tank is below the value set by the "Solid State Thermostat" on the control board when the brew cycle is initiated the fill portion of the brew cycle is delayed. The heating light will begin to flash indicating that the unit is in the brew mode but is not up to temperature. The tank heater will begin heating and when the tank reaches the preset temperature the fill portion of the brew cycle will begin. This feature may be disabled if desired by disconnecting the 1 pole connector located in the black lead which runs from the control board to heater relay. Refer to wiring diagram on page 6. Heater relay is located behind the lower back panel.

Solid State Thermostat maintains temperature within 3 degrees throughout the adjustment range of 170-208 degrees. Full off position is at the extreme left of the adjustment dial. The only wear item, a remotely mounted relay, may be replaced without disturbing the tank or re calibrating the temperature. This also allows the incorporation of several other convenience and safety features as explained below.

Tank Protection Circuit prevents the tank element from coming on before water has reached the heater safety probe located in the tank lid and thus covered the element in the tank when setting the brewer up. This not only prevents premature element failure if element is powered up prematurely but provides a head start for initial tank heat up compared to waiting until the tank is full to turn up thermostat. The probe can also sense if excessive evaporation has occurred in the tank and can signal the board to shut down power to the relay before damage can occur. Additionally if the internal tank temperature sensed by the thermister exceeds a preset limit, it will signal for the element to be shutdown. As a final safety check on the heater circuit the control board continuously monitors how long the element is on. If run time exceeds 30 minutes the tank element is shut down and an error message is produced as part of the "Auto Safety System".

Heater Override allows the tank heater to come on at the start of a brew cycle. This assures a more uniform brew temperature and reduces the recovery time required for rebrewing.

Auto Safety monitors key elements of brewer operation and shuts it down if an error condition occurs. If the tank heater element runs for more than 30 minutes continuously, the fill valve runs for more than 3 minutes continuously or if the temperature sensor opens or shorts this will trigger the system to shut down and to alternate flashing the heating and brewing light thereby alerting the operator to schedule service.

## **WARRANTY**

Newco coffee brewers are warranted against defects in workmanship or materials, under normal use, for 90 days from the date of purchase. Brewer parts are warranted against defect for 12 months from date of purchase.

Liability in all events is limited to the purchase price paid and liability under the aforesaid warranty is limited to replacing or repairing any part or parts which are defective in material or workmanship, and returned to our factory, shipping cost prepaid. No warranty expressed or implied, other than the aforesaid is made or authorized by Newco Enterprises, Inc.

Prompt disposition will be made if item proves to be defective, within warranty. Before returning any item, write or call Newco, or the dealer from whom the product was purchased, giving model number, serial number, and date of purchase, and describe nature of the defect. If damage was incurred during transit to you, file claim with the carrier.

## CONTROL BOARD SETTINGS

The figure below illustrates the control board assembly viewed from the adjustment side. The individual dials cover ranges as noted such as 30-240 seconds or 170-208 degrees. This figure is provided to serve as an aid in interpolating the approximate values for the major interval markings on the actual control board label in the brewer as it was not possible to label the board in this manner due to the proximity of the control adjustment dials. You will note that the values are linear for each dial. That is each tick mark represents a consistent quantity of time or temperature throughout the full range of adjustment. You can use this diagram to determine the approximate settings of your equipment until you are comfortable in determining the values without it.

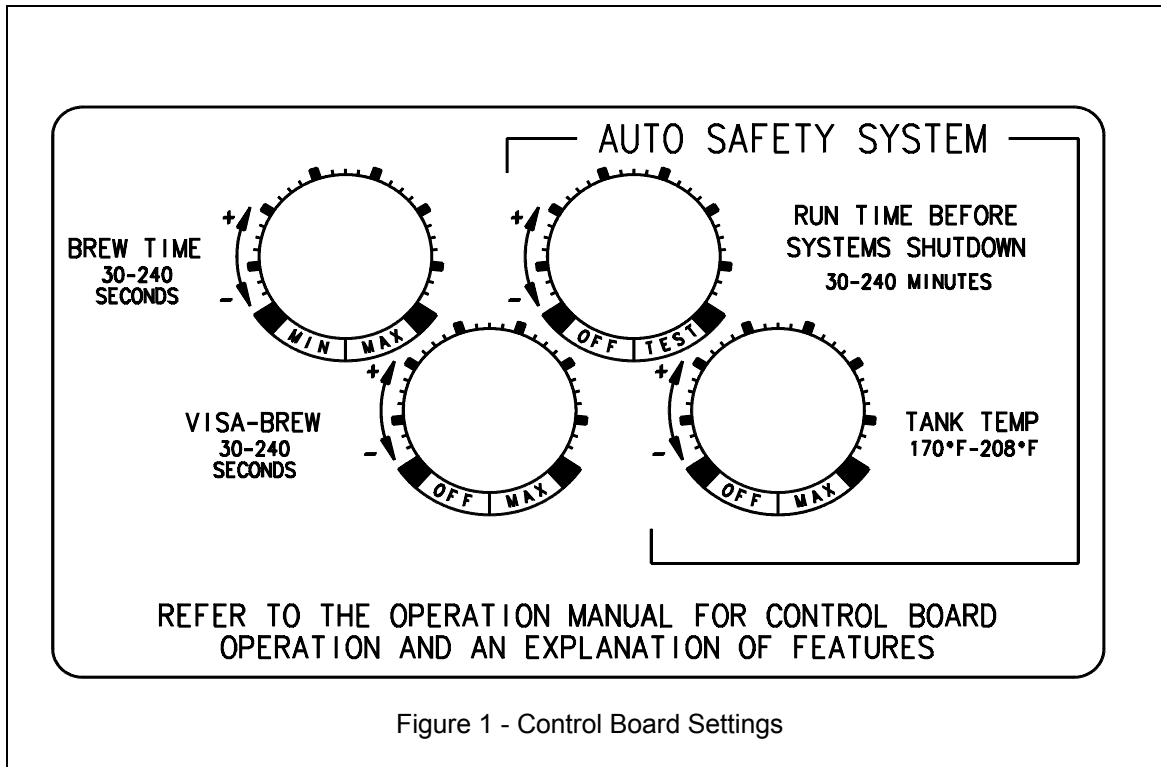

Figure 1 - Control Board Settings

## REPLACEMENT PARTS LIST

Part No	Description	Part No	Description
100022	CORD,POWER 14/3 120V 15AM	102844	SUPPORT,CIRCUIT BRD 3/8"
101035	GROMMET,STRN RELIEF 14/3	102864	SCREW,6-32X1/4 SFHMS(U/C)
100163	BLOCK, TERMINAL 120V	201173	NUT, SPRAYHEAD 7/16-20
100633	THERMOSTAT,LIMIT RED BUT.	108008	TANK ASY 1400W ACE PLUS
102580	ELEMENT,TANK 1750W 120V	108002	TANK LID ASY ACE/PLUS SER
102780	VALVE,SOLENOID S-45 (ACE)	110099	LID MOLD PLASTIC 6Y TANK
102820	VALVE,ASSY S-45	108003	O-RING 1/8 ID X 1/4 OD
102841	MICROSWITCH MOD. (102782)	152207	PLUG,TANK CVR NATURAL SIL
102862	MICRO SWITCH AND BRACKET ASSY	110305	LOW VOLUME FLOW ASSY FLARE/PLUG
108040	CONTROL BOARD ONLY ACE INTELLI BREW	100024	SPRAYHEAD, S/S 5 HOLE
102884	LAMP AUTO/ARM VISA/BREW	100025	GASKET,SPRAYHEAD
104002	SWITCH, MOMENTARY AMBER	102783	SPRAYHEAD TUBE (ACE)
108045	SWI,(RED)STDP MOMENTARY	100409	GASKET, ELEMENT
104015	BEZEL ADAPTOR FOR SWITCH	100190	NUT, 1/2-20 JAM, BRASS
700413	VOLUME SWITCH I,II & III	100440	CLAMP, HOSE LP BREWERS 3/8 OD SIL
105057	HEATER RELAY	152213	TUBING,SIL 3/8ID X 5/8OD
108022	PROBE SPOTWELD WATER LEVEL	152218	SIL TUBING 1/4 ID X 3/8 OD
108023	PROBE SPOTWELD HEATER	102614	TEFLON TUBE & ELBOW ASS'Y ACE
102799	BREW RAIL R.H. ACE BREWER	102770	FAUCET ACE W/RED HANDLE
102800	BREW RAIL L.H. ACE BREWER	700118	BASKET,BREW ASY BLK 8S K
102427	LABEL,ACE/PLUS-DISP		

